

Introduction

In the world of portable consumer products, the single biggest complaint voiced by the consumer is battery life. Whether a notebook PC, a cell phone or a power tool, there is never “enough” battery life. And, as engineers race to put more and more features into systems, this will only get worse.

The solution in vogue today in battery management is gas gauging. While gas gauging can certainly help, by itself it will not result in the Holy Grail of doubling battery life. Other factors, such as cell balancing, battery charging strategies, and the design of the overall battery management system ultimately will determine the degree of battery life improvement designers can realize.

This paper will explore the cell balancing aspects of battery management, and describe the system level inter-relationships that impact useful battery life. Specific design techniques and recommendations will be presented.

Definition of Cell Balancing:

For portable systems requiring 6V or more of operating voltage, battery packs utilize battery cells connected in a series. A series connection results in a pack voltage equal to the sum of the cell voltages. For PCs, the battery pack typically has 3 or 4 cells with nominal voltages of 10.8V or 14.4V. In the majority of these applications, the system requires more capacity than is provided by a single string of battery cells. To increase the capacity, cells are connected in parallel. For example, two 1000mAh cells connected in parallel provide a 2A-hr pack.

Cell balancing is considered when multiple cells in a battery pack are connected in a series. Cell balancing is not needed in a parallel connection of cells, since this configuration is self-balancing. Battery pack cells are balanced when all the cells in the battery pack have the same matched voltage per cell while in a fully charged or discharged state. If one or more of the cells in a pack are not matched then the battery pack is not balanced.

When the cells in the battery pack are not balanced the battery pack has less available capacity, since the capacity of the weakest cell in the series string determines the overall pack capacity. In an unbalanced battery pack, during charge time, one or more cells will reach the maximum charge level before the rest of the cells in the series string. During discharge, the cells that are not fully charged will be depleted before the other cells in the string.

Cells are considered matched when the capacity range of each cell in the series string is within 3%. Li-Ion cells with a 150mV difference at full charge can cause a reduction in battery pack capacity by up to 25%, or more.

Cells are considered balanced when: $Q_{cell1} = Q_{cell2} = Q_{cell3} = \dots = Q_{celln}$

Since $Q = I \times t$ and $Q = C \times V$

$C_{cell1} \times V_{cell1} = C_{cell2} \times V_{cell2} = C_{cell3} \times V_{cell3} = \dots = C_{celln} \times V_{celln}$

Vcell is the electro-chemical potential of the cell dependent on the electrode potential in the Li-ion cell. The Vcell potential for a given set of electrodes, is a standard potential and does not change from cell to cell.

When two cells are unbalanced then $Q_{cell1} \neq Q_{cell2} \rightarrow V_{cell1} \times C_{cell1} \neq V_{cell2} \times C_{cell2}$.

Since the Vcell standard potential does not change we can say that $V_{cell} = V_{cell1} = V_{cell2}$, therefore the unbalanced cells are mismatched because $C_{cell1} \neq C_{cell2}$.

Manufacturers of Li-ion cells today have very good quality control, with cells matched to 50mV or better. Manufacturers of LiPoly cells may have more difficulty reaching this level of matching due to the variations in processing the new type of cells. In either case, but particularly for LiPoly cells, general use can cause cells to become unbalanced. This can happen in a number of ways.

1. Because of slight variations in battery chemistry, nominally similar battery cells may have different charge acceptance levels. Having the same current applied to each cell will gradually result in one cell that accepts more charge and drifts to a higher voltage level.
2. Each cell, no matter how closely matched from the factory, will have slight changes in its ability to maintain a charge over a number of charge/discharge cycles. This again can result in cell mismatches over time.
3. Self-discharge rates, though closely matched, are not equal. Even at room temperature two like cells will self-discharge at different rates, resulting in a mismatch.
4. Temperature changes accelerate the above variations in cell capacity, rates of discharge under load and self-discharge rates. In an application, if there is any mismatch in the temperature of the cells in the pack, as might happen if one side of the pack is close to a heat source, such as the PC microprocessor, the cells gradually assume different capacities.

Example of mismatching:

Consider an example.¹ In a 4S1P pack, cell 1 has a self-discharge rate of 7% per month, the others have a 6% rate. Cell 2 has a charge acceptance rate of 98.9%, the others each have 99%. Cell 3 has cycle-life that degrades to 50% after 1000 cycles, the others degrade to 60%. All cells are initially matched in capacity and state of charge and the temperature is matched for all cells. These variations are all well within the manufacturers specified limits. After 100 charge/ discharge cycles, the pack capacity is reduced by 9%. After 250 cycles the pack capacity is reduced by 27%. By 400 cycles, the capacity is cut in half.

At 400 cycles operating time increases by 50%

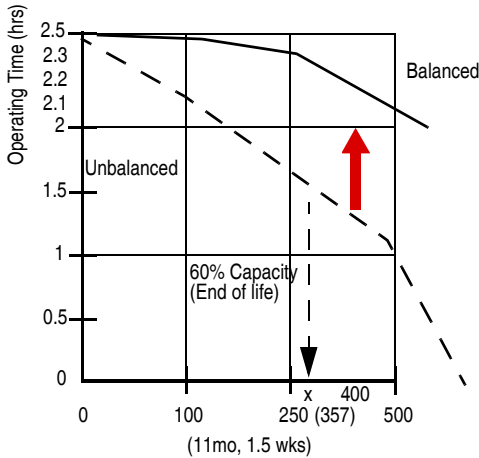

In this same example, a temperature variation between cells of 10°C can double self-discharge rates and can reduce cycle life by 50%. These can significantly affect the balance of the cells in the pack. Since the temperature differential from one end of the pack to the other can be 20°C in a typical application, unbalanced cells can significantly reduce pack performance.

Capacity Saved By Balancing (Theoretical):

A typical Li-ion battery pack for the PC has a capacity that ranges from 1000 ma-hr. to 4000 ma-hr. For our calculation lets assume that we have a battery capacity of 2000 ma-hr. = 2A-hr.

We can say that charge:

$$Q = I \times t = C \times V$$

$$C = \frac{I \times t}{V} \text{ Farads}$$

For 2 A-hr. Li-ion battery pack with a voltage range of 4.2V to 3.0V,

the capacitance is: $C = \frac{2 \times 3600}{1.2} = 6000 \text{ Farads}$

For a cell imbalance of 100mV, the loss of capacity is: $Q = CV = 6000 \times 0.1 = 600 \text{ Coulombs}$. This is a loss of about 5.9% of the total available capacity. This assumes a linear discharge curve. This means that, for a lap top PC consuming an average of 1A, the use of the laptop can be extended by 10 minutes if cell balancing is used. With an actual cell, the capacity loss is greater than 5.9% for a fully charged cell due to the cell having more effective capacity at the higher end of the voltage range. In one study², a 200mV difference (4.1V vs. 3.9V) in fully charged cells at 25°C resulted in a 24% loss of capacity. Balancing the cells to less than 100mV differential is a minimum for balancing circuits. At 100mV, cell balancing keeps the cells to within to within 88-94% of the maximum capacity.

Keeping Cells Balanced:

By monitoring cell voltages and temperature we can track the cell voltage variation. When we detect a cell voltage variation larger than 100mV (or some other value) we can enable a balancing routine that allows the system host to keep the string of cell voltages matched in the battery pack.

The balancing routine “shunts” current around the cell that needs balancing (the highest voltage cell). Typically power transistors are connected in parallel to each cell to control the balancing. When the power transistor is on and the battery pack is being discharged, the effective load on the cell increases to discharge the cell faster than the rest of the cells in the pack. When the power transistor is on and the battery pack is being charged, part of the charge current is diverted around the cell and it will charge at a slower rate than the other cells in the pack. Thus, it is possible to balance the cells during discharge mode or charge mode or both. It is preferred that the balancing routine be performed either during charge or discharge cycle when the cells are nearly fully charged or nearly fully discharged. This is because the change in voltage versus capacity dV/dQ for Li-ion batteries is maximum when the cells are nearly charged and also when the cells are nearly fully discharged. (See Appendix Exhibit 2). Thus it takes less time to correct for a voltage mismatch, assuming a constant charge/discharge current, when the cells are nearly fully charged. For example, a nearly full or nearly empty cell changes about 2mV per mA-h while in the middle of the discharge the cell voltage changes at about 200uV per mA-h. Performing the cell balancing when cells are nearly charged or nearly empty gives a 10x advantage in capacity adjustment over balancing when cells are in the middle of the discharge curve. However, since it is desired to preserve as much charge as possible when the cells are nearly discharged, performing a balancing operation on a cell near the end of its discharge should only be done during a battery charge cycle.

1. Example provided by Marty Brown of Sierra Energy Management Systems.

2. Army Research Laboratory, “Performance of the Sony Lithium-Ion rechargeable Battery,” 12/93 (see Appendix exhibit 1)

Why Is An External Transistor Needed To Keep Cells Balanced?

Assume, in the 2A-hr pack example above, that the battery pack cell configuration is 3S2P. Since the capacities in parallel combinations of cells add (and since we can only measure the combination of 2 cells in parallel) we assume the capacity of each cell is 1 A-hr. Also, assume the capacity value to consider is 6000 Farads.

Let's assume that there is an imbalance of 100mV, one cell is higher by 100mV compared with the other of the cells in the string. The time that it takes to balance the cell is:

$$\Delta t = \frac{C \times V}{I}$$

This time depends on the amount of current drawn from the cell. If the current drawn from the cell is 100ma the time to discharge is approximately:

$$t = \frac{6000 \times 0.1}{0.1} = 6000 \text{sec} = 100 \text{min} = 1.67 \text{hr}$$

If the current drawn out of the cell is 1A then the time to discharge is:

$$t = \frac{6000 \times 0.1}{1} = 6000 \text{sec} = 10 \text{min}$$

If the cell balancing transistors are located in the safety IC of a Li-ion battery pack, controlling 100ma of current may be difficult. This is a large transistor that could generate heat on the device and affect monitoring accuracy. Additionally, balancing multiple cells at 100ma complicates the design due to package power limitations and increases the cost of the monitor IC. A more reasonable current for balancing cells using transistors built into the safety circuit is 10ma. In this case cell balancing takes more than 16 hours.

When connecting the power transistor across the cell, it is not likely that all of the charge will be diverted around the cell. The internal resistance of a Li-ion cell is about 100mΩ. To divert most of the charge around the cell requires connecting a much lower resistance "shunt." However, this would short the battery cell and dissipate more energy than the electronics could handle. A 4mΩ shunt resistance across a 4.2V cell, for example, would draw over 1000 Amps and dissipate over 4400W. So there is a tradeoff between rate of balancing and power dissipation. Faster balancing gives more options and flexibility, but it also results in increased power dissipation which impacts on cost and board space.

Balancing the cells in minutes gives the most flexibility, but requires that the current drawn out of the cell must be high, in the 1A range. This requires a power transistor to handle the current. A power transistor such as this should have an on resistance of about 4Ω, handle the balancing current, dissipate a continuous power of 4 Watts, be packaged in a small surface mount package and be low cost. This could be difficult to find. Alternatively, for a 1A discharge, a 4Ω series resistance could be used, however, this resistor must be rated at 5W or more. This is typically a large resistor and expensive.

What is a reasonable cell balancing time? While there are a number of considerations, the most important factor is that the cell balancing circuit provides more correction than the battery pack creates errors. That is, over any given interval, the cell balancing circuit can overcome the cell imbalances created due to cycling, temperature, self-discharge, and battery chemistry. The requirements can vary, but we can make some assumptions to calibrate the magnitude of the problem.

In the previous example where cells become unbalanced over time, the cells had a 9% reduction in capacity after 100 cycles. This is 0.09% capacity loss per cycle and translates to 1.08mV (based on a 4.2 to 3V range.)

To properly design the balancing circuit mounted in the battery pack we should assume that the balancing circuit should provide more balancing capability than what the history data of the specific application has shown to require. A design for 50% more capacity indicates that the balancing circuit should provide 1.62 mV per cycle adjustment. Using a previous equation and making the assumption that the balance time is 1 hour:

$$I = \frac{6000 \times 0.0018}{3600 \text{sec}} = 1.8 \text{ma}$$

This is not difficult to achieve, even with FETs built into the safety device.

In a more difficult pack design, however, temperature effects should also be considered. A 15°C temperature rise in one cell can result in a voltage differential of 60mV (See Appendix Exhibit 1, 2 and 3). This temperature effect can happen in less than an hour and it might be continuous. Making the assumption that the pack needs to balance this 60mV (plus the 1.08mV resulting from other factors and a 50% buffer) brings the balance voltage to near the 100mV differential. To balance 100mV in an hour, the following equation indicates the current needed to balance the cells:

$$I = \frac{6000 \times 0.1}{3600 \text{sec}} = 166.7 \text{ma}$$

The best compromise is, most likely, to use cell balancing currents between 40mA and 200mA.

Some additional items to consider are:

- If cells are balanced with a 100mA balancing current during charging, it is necessary to start balancing the cells at a relatively low voltage. In a typical pack, a 1A –hr charge current increases an unbalanced cell voltage by approximately 600mV. Since, the balanced cell receives 90% of the charge its voltage increases by 540mV. If 85mV of balancing is needed, then the cell needs to be balanced starting at 3.6V, to complete the balancing operation before the cells reach an over-voltage condition, or the balancing should take place over multiple charge/discharge cycles.
- If balancing is done during cell discharge time, the charge drained from the cell is lost. So balancing should be done with a charger attached so it can supply additional charge to the pack following a balance operation.

Circuit Techniques of Keeping Cells Balanced:

The present circuit technique to balance cells is shown in the figure 1 below:

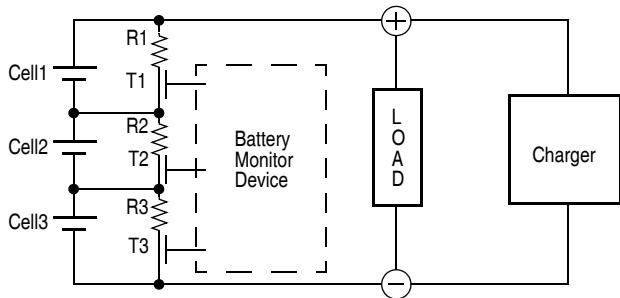

FIGURE 1.

Cells “Cell1” to “Cell3” represent the battery. The balancing circuit is represented by (R1, T1) to (R3, T3). It is assumed that transistors T1 to T3 and resistors R1 to R3 are external to the battery monitor device. It is possible to integrate these

devices in the battery monitor device but the transistors T1 to T3 will have to scale down due to area and power constraints. This means that T1 to T3 on chip will conduct lower current than 100ma which will extend the time to balance a mismatched cell and care must be taken to balance only one cell at a time.

Let us assume that we need to balance Cell1. To perform the balance during battery discharge phase, (charger is off), transistor T1 will be turned on while transistor T2 and T3 are off. The battery cell connection will look as shown in Figure 2.

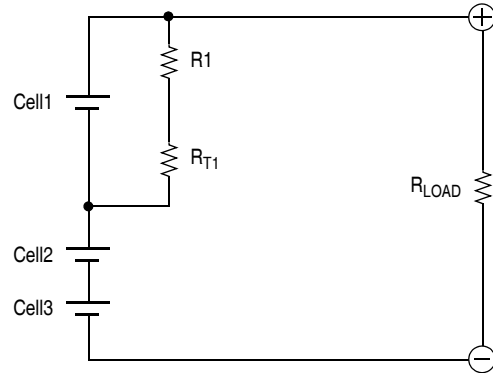

FIGURE 2.

The Thevenin equivalence of the configuration in figure 2 is shown in figure 3.

From the Thevenin equivalence it is clear that the discharge path of Cell1 via transistor T1 does not take away current from Cell2 and Cell3. Thus transistor T1 only discharges Cell1 and similarly transistor T2 only will discharge Cell2 and transistor T3 only will discharge Cell3.

On the other hand, the discharge path of Cell1 depends on the resistance of the load. If the load resistance is high compared to $R1 + R_{T1}$ then most of the discharge current will flow through power transistor T1. On the other hand, if the load resistance is low then some of the discharge current will flow through the load.

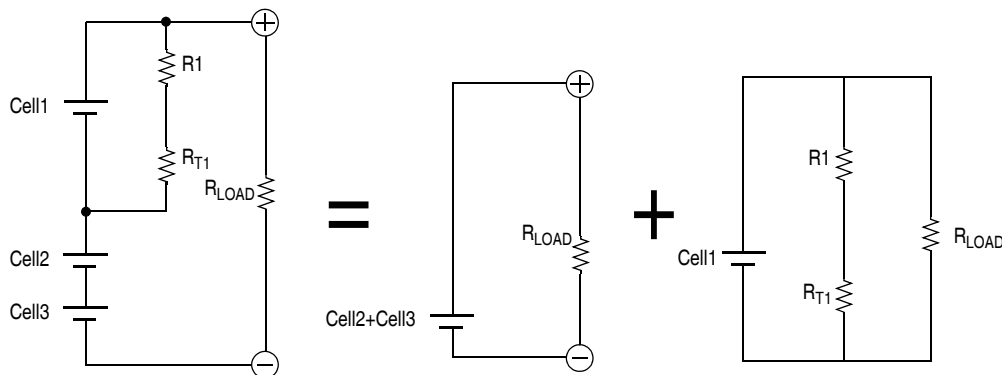

FIGURE 3.

The equivalent discharge resistance is equated to be:

$$R_{Discharge} = \frac{(R_1 + R_{T1}) \times R_{LOAD}}{R_1 + R_{T1} + R_{LOAD}}$$

To decrease the discharge time we need a power transistor with a very low turn on resistor and we need to minimize or eliminate R_1 . The load resistance depends on the system and we have no control of that. It is preferred to have a load resistance that is higher than the $R_1 + R_{T1}$ such that most of the discharge current will flow through the power transistor and not through the load.

If the cell balancing is performed during the charge phase as shown in Figure 4, the charger will deliver a current equal to I_{charge} , where $I_{charge} = I'_{charge} + I_{load}$. The actual current that charges the battery is I'_{charge} and its maximum level is when the load resistance is disconnected. However, if the load resistance is active during the charge phase some of the charge current will flow through the load. During the cell 1 balancing operation, $I'_{charge} = I_1 + I_2$. The magnitude of I_2 with respect to I_1 depends on the on resistance of power transistor T1 and the resistor R1. Typically the resistance of a Li-ion battery is around 100mΩ, so the resistance of $R_1 + R_{T1}$ has to be equal to 100m in order to divert half of the charge current from cell1. Thus, in this example, cell 1 will be charged up at half the rate of cell 2 and cell 3.

Issues With Current Circuit Techniques:

There are numerous issues with the current techniques to keep cells balanced.

Balancing cells during a discharge phase:

1. Dissipates power that is not utilized
2. Takes too long to discharge (because the discharge rate is dependent on the value of the load resistance)
3. Requires external power transistor with low on resistance if balancing needs to be done in a reasonable time

4. Requires low Ω resistor in series with the power transistor to reduce power dissipation by the power transistor
5. A low Ω resistor is large, so it takes more board area and increases cost

Balancing cells during charge phase:

1. During the charge phase the charger voltage across the battery is larger by about 1.5V to 2V to allow charging to take place
2. Measuring the cell voltage during charge is not accurate and can lead to premature cell balancing
3. Voltage spikes on the output of the charger as a result of voltage switching and inductive resonance of the charger
4. Requires an external power transistor with low on resistance to divert current from the cell to be balanced
5. Due to the low resistance of the unbalanced cell it is not possible to divert all the charge current from the unbalanced cell. Therefore, some amount of current will flow through the unbalanced cell but at a lower rate compared with the other balanced cells in the battery pack. This requires cell balancing to start at a lower voltage to avoid violating Li-ion cell safety limits.

Recommendations for Cell Balancing:

The recommended way to implement cell balancing is to perform balancing during the charge phase. During the charge phase the device in the battery pack will control the charger. It is recommended that the charger periodically deliver a pulse of current for a short duration. The battery pack voltage and cell voltages are measured during the rest time between the current pulses. If a mismatch develops between the cells, then the balancing power transistor is turned on and the unbalanced cell will be charged with less current. During the rest time the cells will be measured again and if balancing is reached the power transistor will be turned off.

The duration of the current pulse can vary. After the battery is fully discharged, the current charging period can last longer and the measurement period between current charging can be less

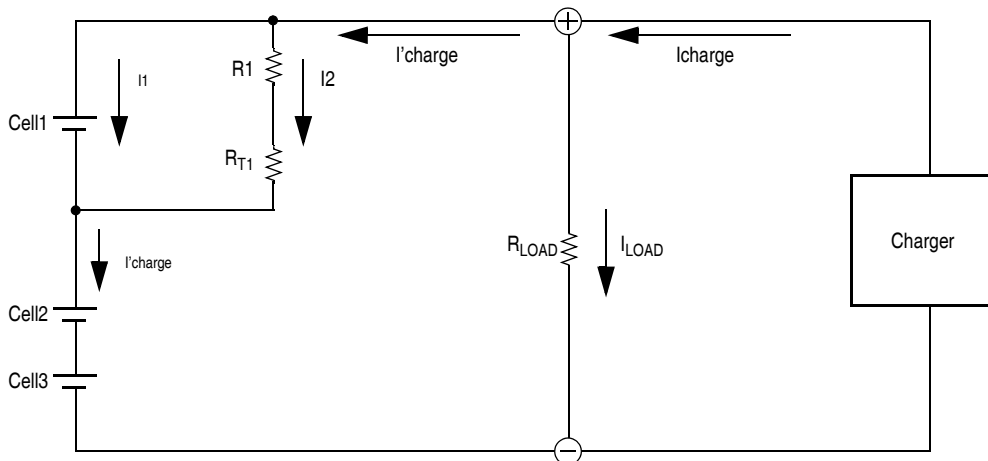

FIGURE 4.

frequent. As the battery voltage increases and the battery is getting closer to the full charge limit, the current pulse duration can decrease and the frequency of battery voltage measurement can increase. If any cell in the battery pack reaches over-voltage level during charge time before the cells are balanced, then the period of discharge must take place by extending the rest period to allow the particular battery pack cells to stay in the safe zone. In this case several cycles of charge and discharge should take place until all the cells are equalized.

Improving the control on the charger, such that the current that the charger delivers can be increased or decreased, is very important. If the temperature during charge exceeds a pre-assigned level, the battery pack can request less current from the charger to help reduce the temperature while still charging the battery but at a lower rate.

Measuring the voltage of each cell monitors cell balancing. It is important that the load is constant during the monitoring period, so while the voltage for each cell is monitored the current consumed by the battery pack should not change.

Pack Balancing Electronics

In order to implement cell balancing, the battery pack needs a number of components. It must be able to:

- Accurately monitor the voltage on each cell independently. This requires differential amplifiers that can operate with a

supply voltage of up to 20V, have an input differential range of between 2 and 4.5V and have an accuracy of better than 10mV.

- Determine the highest voltage cell and the voltage differential between all the cells. This requires a number of hardware comparators or a computer controlled comparison mechanism.
- Make decisions on the cell voltage differences and initiate cell balancing. This is either a microcontroller, or a hardware state machine.
- Control the cell balancing FETs. This needs to be able to turn on FETs with source voltages that range between 3V and 17V.

These components must be integrated as much as possible to avoid a significant increase in the cost of the battery pack electronics. The Intersil X3100 Safety/Monitor IC shows an example of one way to integrate these components. This device provides a monitor on each cell voltage. These monitors are differential op amps. An analog multiplexer allows a microcontroller (with built-in A/D converter) to read each voltage. Through software on the IC, the pack can determine the balancing error and implement corrective actions. The X3100 also provides the FET drivers to eliminate the need to add level shifting circuits to drive high voltage from the 5V powered microcontroller.

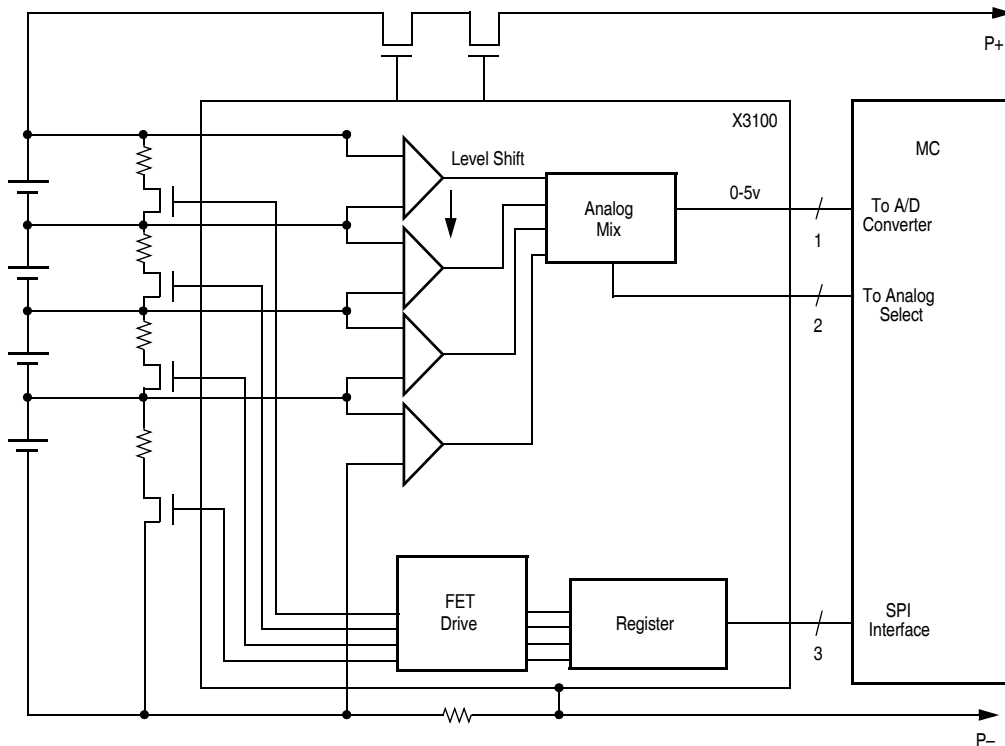

Conclusion

Cell balancing can increase the useable capacity to the system by more than 20% and can improve the life of the battery pack. This advantage is more important if there is a temperature gradient across a cell pack, since a temperature gradient accelerates cell imbalances. Adding cell balancing, however, is not a universal solution. Many circuits are required to implement a cell-balancing operation. This adds complexity to the design. Limitations in current handling capability of cell balancing components result in increased cell balance time. To meet the needs of those applications that require cell balancing, new devices integrate elements of the cell balancing control to reduce the cost. Devices like the X3100 from Intersil integrate the voltage monitor circuits and FET control elements and allow an external microcontroller to evaluate and control cell balancing. This approach gives the battery pack designer flexibility to create a battery pack to meet the precise needs of the system.

Appendix

Exhibit 1

Discharge capacity at 0.5 amperes to 2.5 volts at different temperatures after charge to 4.25 volts at the same temperature

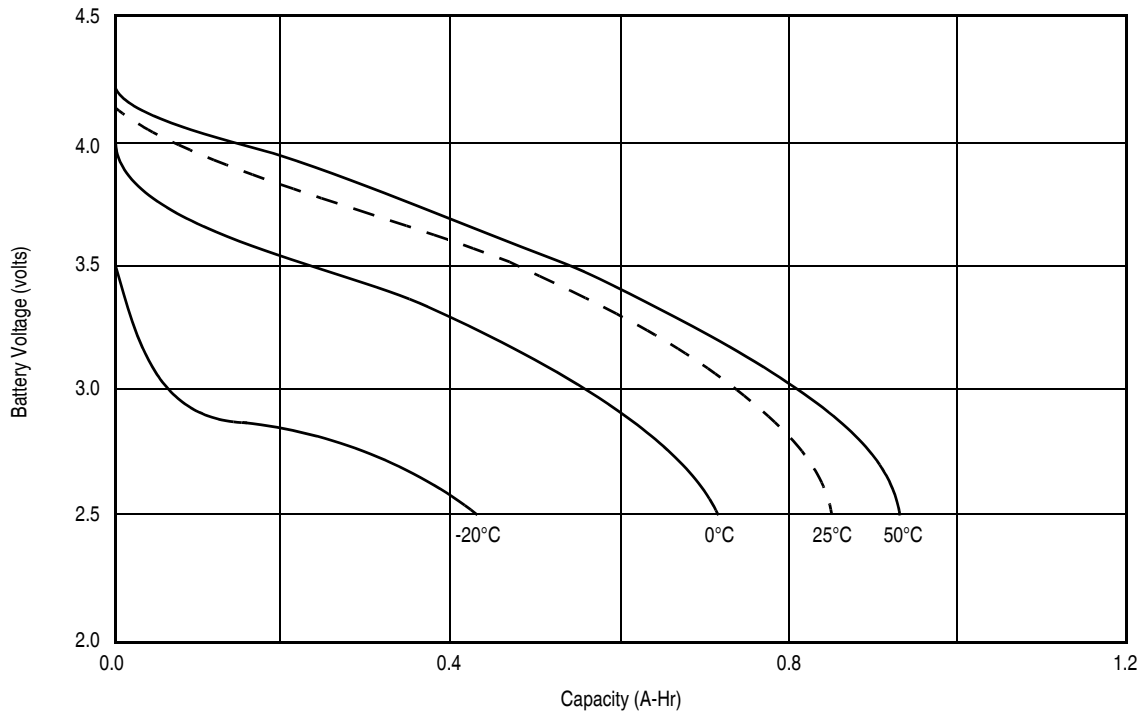

Source: Army Research Laboratory, "Performance of Sony Li-ion Rechargeable Battery," 12/93

Exhibit 2

DISCHARGE CHARACTERISTICS AT C RATE & VARIOUS TEMP

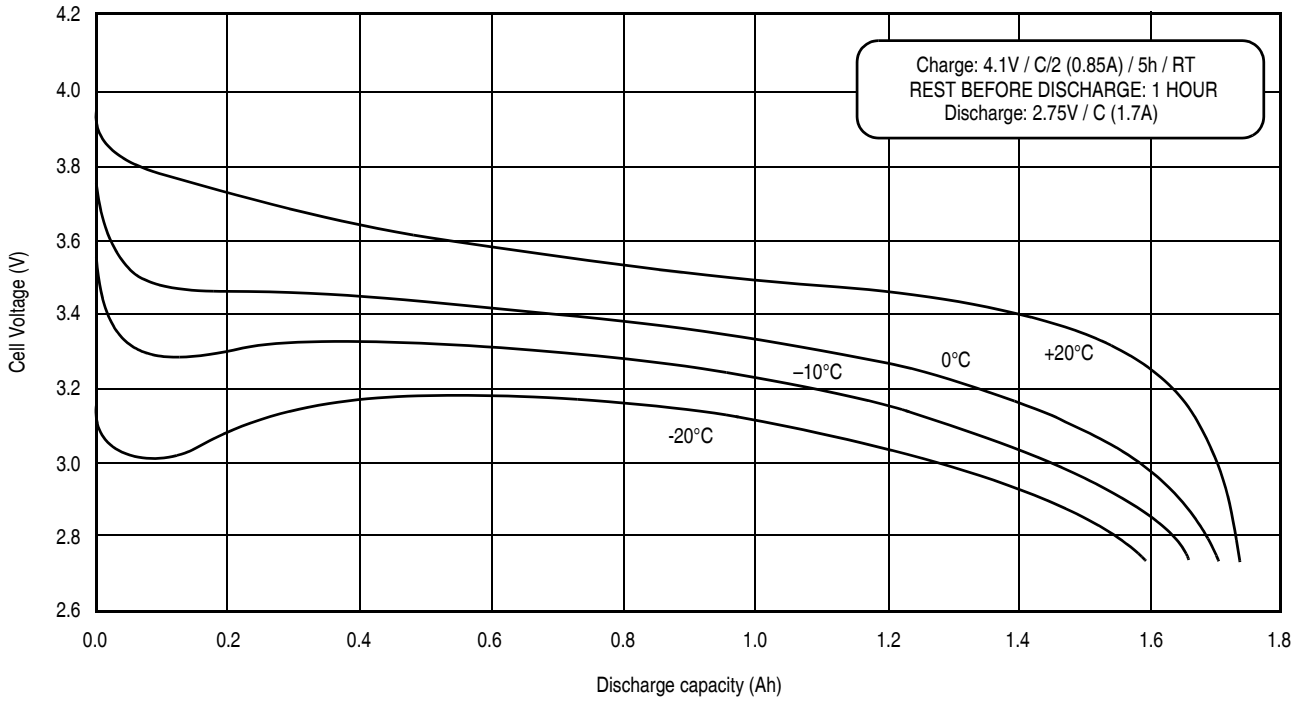
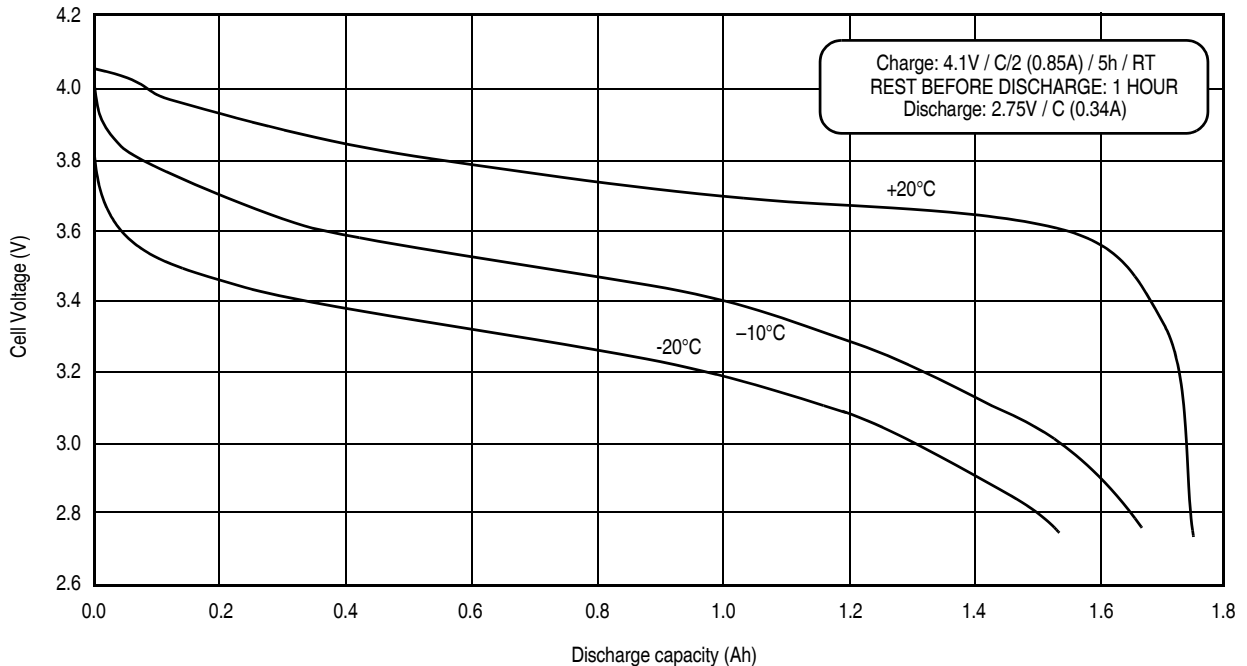
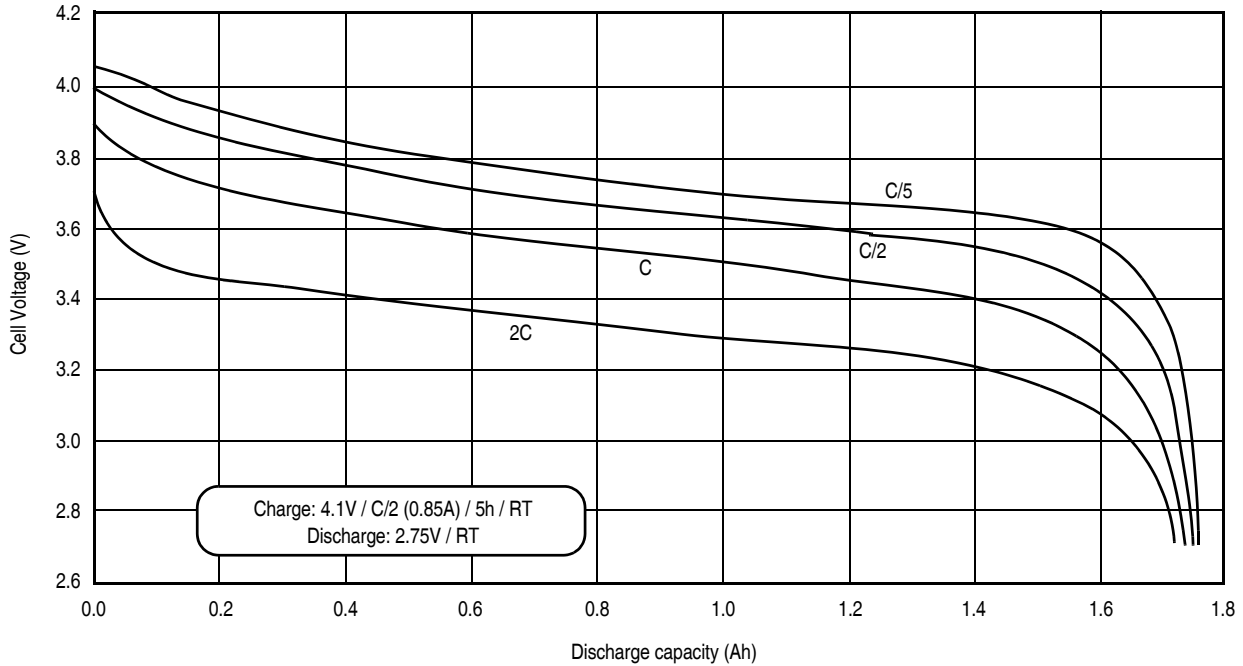

Exhibit 3

DISCHARGE CHARACTERISTICS AT C/5 RATE & VARIOUS TEMP



DISCHARGE CHARACTERISTICS AT 20°C & VARIOUS CURRENTS



All Intersil U.S. products are manufactured, assembled and tested utilizing ISO9000 quality systems. Intersil Corporation's quality certifications can be viewed at www.intersil.com/design/quality

Intersil products are sold by description only. Intersil Corporation reserves the right to make changes in circuit design, software and/or specifications at any time without notice. Accordingly, the reader is cautioned to verify that data sheets are current before placing orders. Information furnished by Intersil is believed to be accurate and reliable. However, no responsibility is assumed by Intersil or its subsidiaries for its use; nor for any infringements of patents or other rights of third parties which may result from its use. No license is granted by implication or otherwise under any patent or patent rights of Intersil or its subsidiaries.

For information regarding Intersil Corporation and its products, see www.intersil.com